

RVS-DX



Digital Soft Starter with internal ByPass 8-1100A, 220-690V



Instruction Manual

Ver. 26/12/2012



2. SAFETY & WARNINGS

2.1 Safety

	1	Read this manual carefully before operating the equipment and follow its instructions.
	2	Installation, operation and maintenance should be in strict accordance with this manual, national codes and good practice.
	3	Installation or operation not performed in strict accordance with these instructions will void manufacturer's warranty.
	4	Disconnect all power inputs before servicing the soft-starter and/or the motor.
	5	After installation, check and verify that no parts (bolts, washers, etc) have fallen into the starter.
	6	During shipping, the soft-starter might have been roughly handled, therefore, it is recommended to initialize the soft-starter by connecting supply voltage prior to operating the soft-starter with a motor

2.2 Attention

	1	This product was designed for compliance with IEC 947-4-2 for class A equipment.
	2	RVS-DX 8 - 170 are UL and cUL approved. RVS-DX 210 - 1100 are designed to meet UL and cUL requirements.
	3	Use of the product in domestic environments may cause radio interference, in which case, the user may be required to employ additional mitigation methods.
	4	Utilization category is AC-53a or AC53b, Form 1. For further information, see Technical Specification

2.3 Warnings

	1	Internal components and PCBs are at mains potential when the RVS-DX is connected to mains. This voltage is extremely dangerous and will cause death or severe injury if contacted.
	2	When RVS-DX is connected to mains, even if control voltage is disconnected and motor is stopped, full voltage may appear on starter's output and motor's terminals.
	3	The starter must be grounded to ensure correct operation, safety and to prevent damage.
	4	Check that Power Factor capacitors and overvoltage devices are not connected to the output side of the soft starter. If PF capacitors are used, they must be connected on the line side of the RVS-DX . If a main contactor is used in combination with RVS-DX, the capacitors must be disconnected from RVS-DX when contactor is open.
	5	Do not interchange line and load connections

The company reserves the right to make any improvements or modifications to its products without prior notice.

3. TECHNICAL DATA

3.1 Introduction

The RVS-DX is a third generation, highly sophisticated and reliable starter designed for use with standard three-phase, three-wire, squirrel cage, induction motors.

It provides the best method of reducing current and torque during motor starting.

The RVS-DX starts the motor by supplying a slowly increasing voltage, providing soft start and smooth acceleration, while drawing the minimum current necessary to start the motor.

The RVS-DX is equipped with internal by-pass controlled by its micro-controller. The by-pass closes after the end of the starting process, thus reducing heating and saving power.

3.2 Rating and frames sizes

Starter type	Starter FLC [A]	Frame Size	Dimensions WxHxD [mm]	Weight [Kg]
RVS-DX 8	8	D1	120x232x122	3.0
RVS-DX 17	17	D1	120x232x122	3.0
RVS-DX 31	31	D1	120x232x122	3.0
RVS-DX 44	44	D1	120x232x122	3.0
RVS-DX 58	58	D2	129x275x182	5.2
RVS-DX 72	72	D2	129x275x182	5.2
RVS-DX 85	85	D3	129x380x182	8.5
RVS-DX 105	105	D3	129x380x182	8.5
RVS-DX 145	145	D4	172x380x192	12.5
RVS-DX 170	170	D4	172x380x192	12.5
RVS-DX 210	210	D5	380x455x295	30.2
RVS-DX 310	310	D5	380x455x295	30.2
RVS-DX 390	390	D6	350x550x310	55
RVS-DX 460	460	D7	460x600x319	65
RVS-DX 580	580	D8	460x643x319	75
RVS-DX 650	650	D8	460x643x318	80
RVS-DX 820	820	D8	460x643x318	90
RVS-DX 950	950	D9	560x833x334	100
RVS-DX 1100	1100	D9	560x833x334	100

Notes:

Refer to section 5 on page 14 for detailed dimensions.

3.3 Starter Selection

The starter should be selected in accordance with the following criteria:

3.3.1 Motor current & Starting Conditions

Select the starter according to motor's Full Load Ampere (FLA) - as indicated on its nameplate (even if the motor will not be fully loaded).

The RVS-DX is designed to operate under the following maximum conditions:

Ambient Temperature [°C]	Starting Current [A]	Acceleration Time [sec]
40	300% \times In	30
	350% \times In	20
	400% \times In	5

Max. Starts per Hour: four (4) starts per hour at maximum ratings and up to 10 starts per hour at light load

applications (consult factory).

Note:

For very frequent starts (inching applications) the inching current should be considered as the Full Load Current (FLC) (consult factory).

3.3.2 Mains Voltage (line to line)

Four Main Voltage levels are available: 400V, 480V, 600V and 690V (690V only available for RVS-DX 390A and up).

Note:

400V applies for 230 to 400V.

3.3.3 Control Voltage

The Control Voltage (terminals A1(~) – A2 (N) operates the electronic circuitry and the bypass.

Two voltage levels are available, selectable by internal jumper:

230VAC + 10%-15%, 50/60 Hz (standard)

115VAC+ 10%-15%, 50/60 Hz

Refer to section 8.1 on page 49 for instructions on setting control voltages on site.

3.3.4 Other Options

More options are available for the RVS-DX. (Refer to section 3.3.6 on page 7.):

Communication, Analog card, harsh environment treatment, , Remote panel,UL & cUL approval .

3.3.5 Starter selection tables for various voltage ratings.

1	The starter selection table below concern standard, 1500r.p.m. 50Hz, three-phase motors.
2	These values are given for guidance and may vary according to motor manufacturer and depending on the number of poles.
3	It is the user's responsibility to make sure that motor's FLA will never exceed Starter's FLC.

3.3.5.1 Starter selection for 230V, 400V, 480V, 600V

Starter type	Starter FLC [A]	Motor kW @230V, starter "In-Line" [kW]	Motor kW @230V, starter "Inside Delta" [kW]	Motor kW @400V, starter "In-Line" [kW]	Motor kW @400V, starter "Inside Delta" [kW]	Motor kW @480V, starter "In-Line" [kW]	Motor kW @480V, starter "Inside Delta" [kW]	Motor kW @600V, starter "In-Line" [kW]	Motor kW @600V, starter "Inside Delta" [kW]
RVS-DX 8	8	1.5	3	3	6.5	4	8	5.5	9
RVS-DX 17	17	4	8	8	12.5	9	15	12.5	22
RVS-DX 31	31	8	15	15	25	18.5	30	25	40
RVS-DX 44	44	12.5	22	22	37	25	45	30	59
RVS-DX 58	58	15	30	25	51	37	59	45	80
RVS-DX 72	72	20	37	37	59	45	80	59	100
RVS-DX 85	85	25	40	45	80	55	90	59	110
RVS-DX 105	105	30	55	55	90	59	110	80	147
RVS-DX 145	145	40	75	75	132	90	160	110	200
RVS-DX 170	170	51	90	90	160	110	200	140	250
RVS-DX 210	210	59	110	110	184	140	220	160	295
RVS-DX 310	310	90	160	160	257	200	355	257	450
RVS-DX 390	390	110	200	200	355	257	475	315	560
RVS-DX 460	460	140	220	250	400	295	560	400	670
RVS-DX 580	580	180	315	315	560	400	670	500	
RVS-DX 650	650	c	c	c	c	c	c	c	c
RVS-DX 820	820	250	450	450	670	560		670	
RVS-DX 950	950	295	500	500		670		-	
RVS-DX 1100	1100	355	560	600				-	

Note:

C – Consult factory

4. RECOMMENDED WIRING SCHEME

4.1 Typical wiring diagram

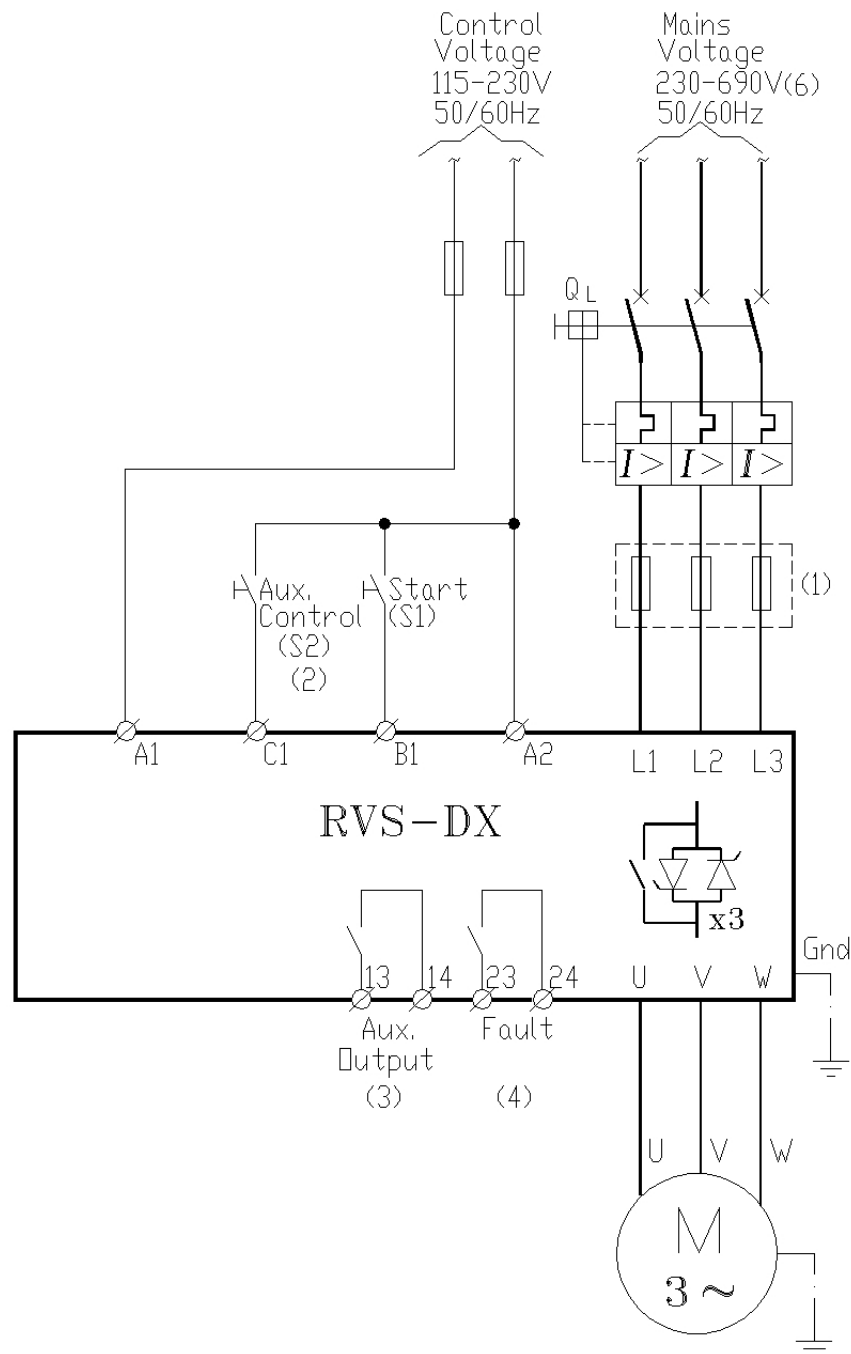
**Notes:**

- (1) - Use fuses for type 2 coordination. Refer to section 4.3.1 on page 10
- (2) - For Aux. input programming refer to section 7.6.9 on page 42
- The use of solid state relays to control the digital inputs B1 and C1 is prohibited
- (3) - For Aux. output programming refer to section 7.6.9 on page 42
- (4) - Fault relay can function as a "Fault" relay or as a "Fail-Safe" relay. For Fault relay programming refer to section 7.6.9 on page 42
- (5) - When emergency Stop switch is required it is recommended to trip a series contactor or the feeding circuit breaker. (Not shown)
- (6) - Mains voltage of 230-600V available to all models. (need to be specified)
Mains voltage of 690V only available for RVS-DX390A and up.

4.2 Power wiring scheme for “Inside-Delta” Connection

(Refer to section 4.3.9 on page 12)

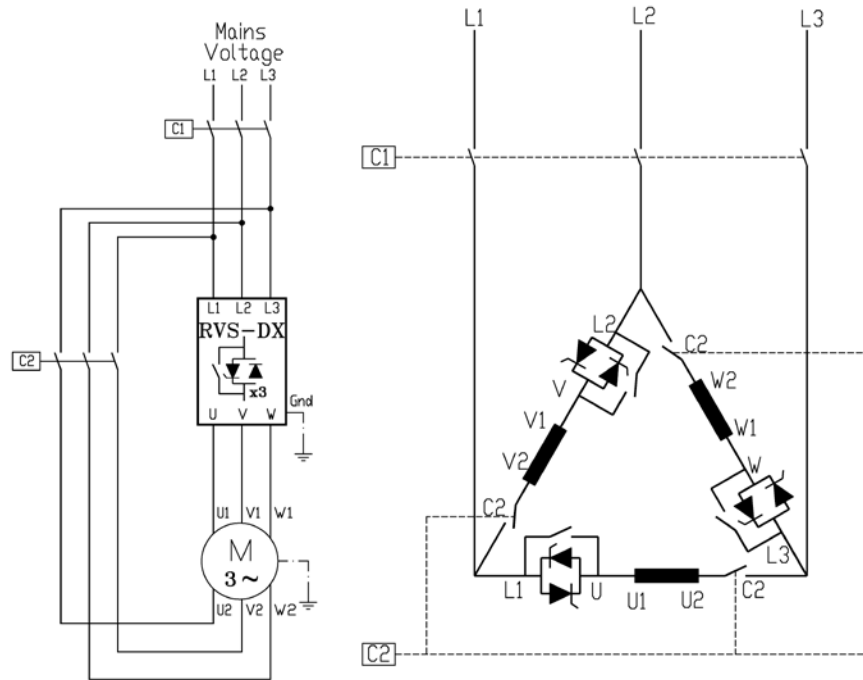

Connecting RVS-DX INSIDE DELTA

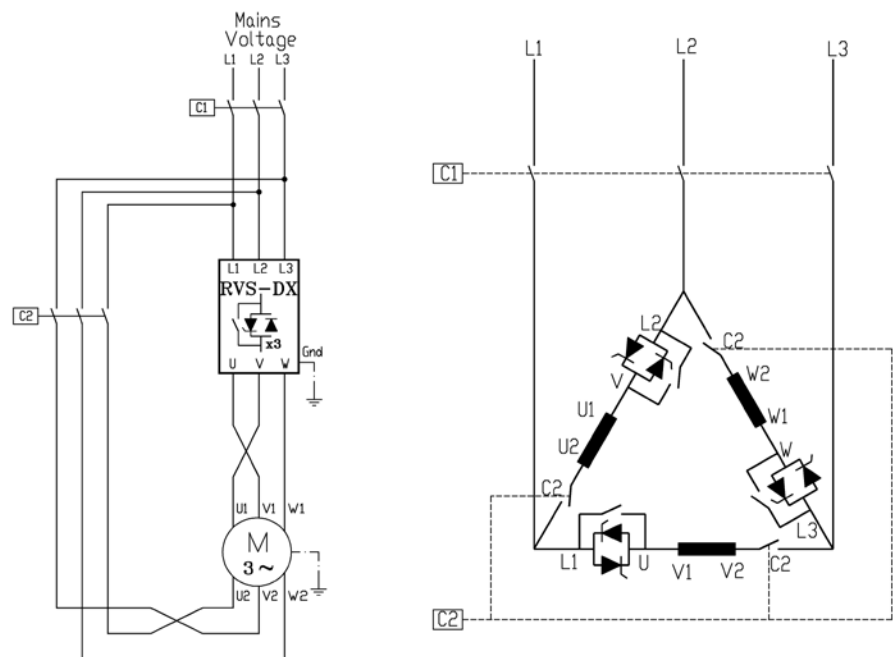

Reverse speed with RVS-DX connected INSIDE DELTA.

Notes:

When installing the RVS-DX INSIDE DELTA, it is highly recommended to use a line contactor (C1) or INSIDE DELTA contactor (C2) in order to avoid a destruction of the motor in case of a shorted SCR in the RVS-DX. If a contactor is connected Inside the Delta (C2) only, motor terminals are “live” (full voltage) even when contactor is open.

4.3 Wiring Notes

WARNINGS!

When mains voltage is connected to the RVS-DX, even if control voltage is disconnected, full voltage may appear on the starter load terminals. Therefore, for isolation purposes, it is necessary to connect an isolating device before the starter.

Power factor correction capacitors and overvoltage devices must not be installed on starters load side. When required, install capacitors or overvoltage devices on starter's line side.

4.3.1 Short Circuit Protection

For “class 2 coordination”, protect the starter against a short circuit by thyristor Protection Fuses for I²t and fuses as in dictated in the following table:

RVS-DX	Max. thyristor I ² t [A ² Sec]	BUSSMAN		GEC ALSTOM		SIBA		FERRAZ – SHAWMUT (IEC Style 690/700V)	
		Rate [A]	P/N	Rate [A]	P/N	Rate [A]	P/N	Rate [A]	P/N
RVS – DX 8	400	30	FWP 30B	32	B210612			32	URD 000-32
RVS – DX 17	5,000	50	FWP 50B	63	B210615			63	6.6URD30D11A0063
RVS – DX 31	10,000	90	FWP 90B	100	V320063			100	6.6URD30D11A0100
RVS – DX 44	12,000	125	FWP 125A	100	X320063			100	6.6URD30D11A0100
RVS – DX 58	15,000	150	FWP 150A	125	X320065			125	6.6URD30D11A0125
RVS – DX 72	18,000	175	FWP 175A	160	B320069	200	SQB1-200	200	6.6URD30D11A0200
RVS – DX 85	40,000	200	FWP 200A	200	E320371	200	SQB1-200	200	6.6URD30D11A0200
RVS – DX 105	60,000	250	FWP 250A.	250	J320375	250	SQB1-250	250	6.6URD30D11A0250
RVS – DX 145	100,000	300	FWP 300A	315	M320079	315	SQB1-315	315	6.6URD30D11A0315
RVS – DX 170	140,000	400	FWP 400A	350	Y320480	350	SQB1-350	350	6.6URD30D11A0350
RVS – DX 210	200,000	500	FWP 500A	450	D320485	450	SQB1-450	450	6.6URD30D11A0450
RVS – DX 310	600,000	700	FWP 700A	630	H320489	630	SQB1-630	630	6.6URD31D11A0630
RVS – DX 390	700,000	700	FWP 700A	800	T320591	800	SQB1-800	800	6.6URD31D11A0800
RVS – DX 460	800,000	800	FWP 800A	900	V320592	900	SQB1-900	900	6.6URD32D11A0900
RVS – DX 580	1,200,000	1000	FWP 1000A	1000	W320593	900	SQB2-900	1000	6.6URD32D11A1000
RVS – DX 650	2,000,000	1200	FWP 1200A	2X 700	2X S320590	1100	SQB2-1100	1250	6.6URD33D11A1250
RVS – DX 820	2,000,000	1200	FWP 1200A	2X 700	2X S320590	1100	SQB2-1100	1250	6.6URD33D11A1250
RVS – DX 950	4,500,000	2X 1000	2X FWP 1000A	2X 900A	2X V320592		SQB2-1250	1600	6.6URD33D11A1600
RVS – DX 1100	4,500,000	2X 1000	2X FWP 1000A	2X 900A	2X V320592		SQB2-1250	1600	6.6URD33D11A1600

Notes:

1. The above table is for maximum starting current of 400% of FLC, maximum starting time of 5 sec and rated voltage up to 690V V.
2. Rating may change with different external conditions such as ambient temperature, forced cooling etc. Refer to fuse manufacturer catalogs to confirm correct values.

4.3.2 Transient Protection

Line transient voltages can cause a malfunction of the starter and damage to the thyristors. All RVS-DX starters incorporate Metal Oxide Varistors (MOV) to protect from normal line voltage spikes.

When higher transients are expected, additional external protection should be used (consult factory).

4.3.3 Control Supply (Terminals A1, A2)

220-240V or 110-120V, 50/60Hz is required to power the electronic circuitry and the bypass. Factory set value is indicated on the starter's side label.

This voltage can be from a grounded or ungrounded mains system.

In models up to 310A, voltage level 110V /220V can be changed in the field. (Refer to section 8.1 on page 49)

4.3.4 Start/Stop (or 4.3.4momentary start) Input (terminal B1)

Input from a maintained contact. Close contact between A2 and B1 to soft start the motor.

To stop the motor open the contact.

If Deceleration time is set to a value other than 0 seconds the motor will soft stop.

If Deceleration time is set to 0 seconds the motor will stop immediately. (Refer to section 7.6.5 on page 35)

If Aux Input is set as Start / Stop, then terminal B1 is used as momentary N.O. Start input and input C1 is used as maintained N.C Stop input. (Refer to section 7.6.9 on page 42)

For emergency stop of the motor disconnect control voltage from A1, A2 terminals.

4.3.5 **Aux. Input (terminal C1)**

Input from a maintained contact, connected between terminals A2 and C1 to operate as programmed input.

Aux. Input can be programmed as one of six options:

- (1) Dual Adjust
- (2) Generator Function
- (3) Slow Speed / Reverse
- (4) External fault
- (5) Remote reset after fault has been removed.
- (6) Start / Stop (terminal C1 can be used as a maintained N.C Stop input and terminal B1 as momentary N.O. Start input – refer also to section 4.3.4 above.

For Aux. Input programming refer to section 7.6.9 on page 42.

4.3.6 **Auxiliary output relay (terminals 13, 14)**

Voltage free, N.O , 8A, 250VAC, 1800VA max.

The contact incorporates 0-60 seconds On & Off delays. The auxiliary output relay can be programmed to operate in two modes:

1. IMMEDIATE - Close its contact at start signal (after programmed “on delay” time has elapsed) and open its contact at the end of deceleration time (if any) (after programmed “off delay” time has elapsed).
2. END OF ACCEL. - Close its contact at end of soft start (after programmed “on delay” time has elapsed) and open its contact at the beginning of soft stop (if any) (after programmed “off delay” time has elapsed).

The relay contact will open also in case of a fault or upon control supply outage.

This output is generally used to:

- (1) Release the brake of a brake motor.
- (2) Interlocking with other systems.
- (3) Signalling.

For Aux. output programming refer to section 7.6.9 on page 42.

4.3.7 **Fault Contact (terminals 23, 24)**

Voltage free, N.O , 8A, 250VAC, 1800VA max.

The contact changes its position upon fault and returns to its original position after fault has been removed and starter was reset. When disconnection of Control Supply the contacts will be closed. Fault relay can function as a “Fault” relay or as a “Fail-Safe” relay.

For Fault relay programming refer to section 7.6.9 on page 42.

4.3.8 **Options description**

4.3.8.1 Analogue I/O (option # 5) (terminals T1, T2, Gnd, Out (-), Out (+))

The Analogue option incorporates two functions:

- Thermistor input
- Analogue output

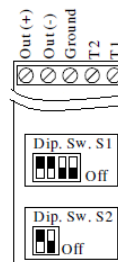

Analogue P.C.B. layout

Thermistor input (terminals T1, T2)

Programmable as PTC or NTC type thermistor. Trip value is adjustable between 1-10K, preset delay of 2 Sec.

For thermistor input programming refer to section 7.6.8 on page 40.

Ground Terminal (terminal Gnd)

Connect thermistor and / or Analogue output shield to this ground terminal.

Analogue Output (terminals Out (+), Out (-))

Dip switches allow selection between: 0-10VDC, 0-20mA, 4-20mA

Analogue value can be programmed via the key pad in I/O PROGRAMMING PARAMETERS page to one of the values as follows: (refer to section 7.6.9 on page 42.)

- A. 0....200% of FLA (Default setting)
- B. 0....200% of Pn
- C. Power factor (POWER FACTOR & POWER measurement only available in RVS-DX58A and up)

Dip No.	4-20 mA*	0-20 mA	0-10VDC
Dip-Sw. S1 # 1	On	On	Off
Dip-Sw. S1 # 2	On	On	Off
Dip-Sw. S1 # 3	Off	Off	On
Dip-Sw. S1 # 4	Off	Off	On
Dip-Sw. S2 # 1	On	Off	Off
Dip-Sw. S2 # 2	No use	No use	No use

* Default

Notes:

- It is important that the RVS-DX is properly grounded, and control module is tightly fastened to the power section.
- Use twisted shielded cable for thermistor connection.

4.3.8.2 RS-485 Communication (option # 3M) (terminals out(-).Out(+))

Standard RS485, Half Duplex with MODBUS Protocol, baud rate 1200, 2400, 4800, 9600 BPS.

Twisted shielded pair should be used, connect shield to ground a PLC/Computer side. Terminals (-) & (+) must be wired to control supply for operation in communication mode. Leave terminal NC not connected.

Note: When DeviceNet option is required an external device will be provided with the option. This gateway is connected via 2 wires to the optional Modbus terminals.

Refer to section 7.6.10 on page 44.

4.3.9 **“Inside-Delta” mode**

4.3.9.1 General information

When the RVS-DX is installed “Inside Delta”, the individual phases of the Starter are connected in series with the individual motor windings (6 conductor connections as with the star-delta starter). The soft starter must only conduct about 67 % (=1\1.5) of the rated motor current. This ensures the use of a significantly smaller device.

For example:

For a motor with a rated current of 155A motor, a 170A starter will be selected to operate “In-Line”. For “Inside Delta” starter, we calculate (155 x 67% = 104A) and select a 105A starter. Less heat dissipates in the cabinet vs. the standard “In-Line” connection.

4.3.9.2 Notes on "Inside Delta" connection

- "Inside Delta" requires 6-wire to the motor.
- Wrong motor connection will cause serious damage to the motor windings.
- When installing the RVS-DX "inside delta" it is highly recommended to use a contactor in series to the RVS-DX or upstream (after motor protection) in order to avoid a destruction of the motor in case of a shorted SCR in the RVS-DX.
- The sinusoidal shape of the current is imperfect (since each phase is separately fired and not influenced by other phase firing).
As a result, higher harmonic content is incurred (THD), which can be as high as twice the THD value as in the standard "In-Line".
- Higher motor heating is expected for the same motor size (due to the higher THD).
- Phase sequence must be correct; otherwise, "Phase Sequence fault" will trip the starter immediately (without any damage).
- Higher torques can not be obtained
- Factory preset - features and functions when "Inside Delta" mode is configured:
 - No Pulse Start.
 - No curve selection (Curve 0 !! only).
 - No Slow Speed
 - No Phase sequence "Off" mode

Note :

For a high starting torque process, it is recommended to use the starter in the "In Line" connection.

WARNINGS!	Beware! Wrong connection of the starter or the Motor, will seriously damage the motor.
	When using "Inside delta" connection: 1. It is highly recommended to use a contactor in series to the RVS-DX or upstream (after motor protection) in order to avoid a destruction of the motor in case of a shorted SCR in the RVS-DX. 2. If Contactor is connected Inside the Delta, motor terminals are "live" (full voltage) even when contactor is open.

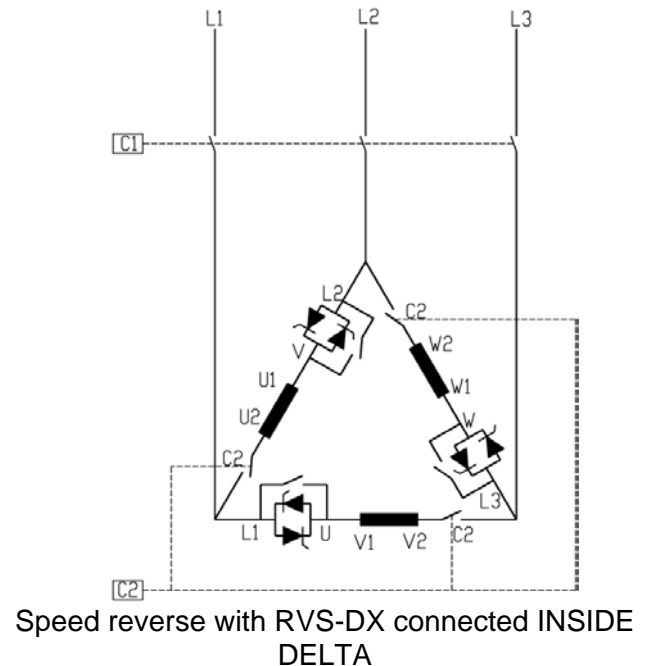
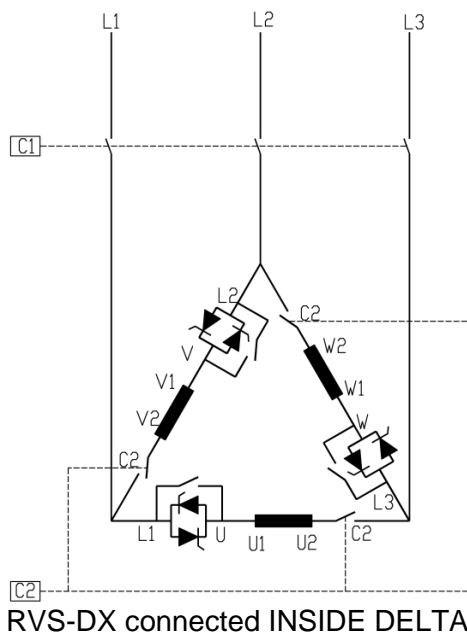

- (1) C1 is a line contactor.
 - (2) C2 is an "Inside Delta" contactor.
 - (3) U1-U2, V1-V2, W1-W2 are motor's windings.
 - (4) L1-U, L2-V, L3-W are RVS-DX controlled phases.
- Refer also to section 4.2 page 9.

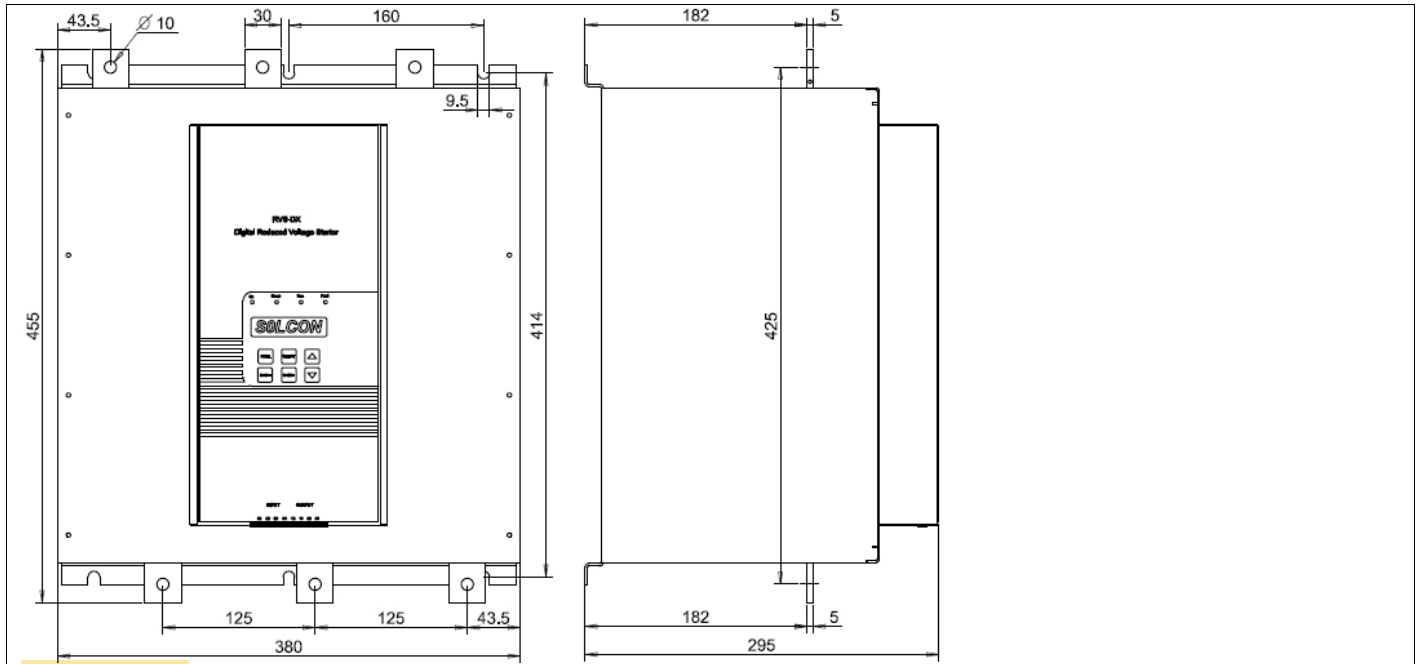

RVS-DX 310

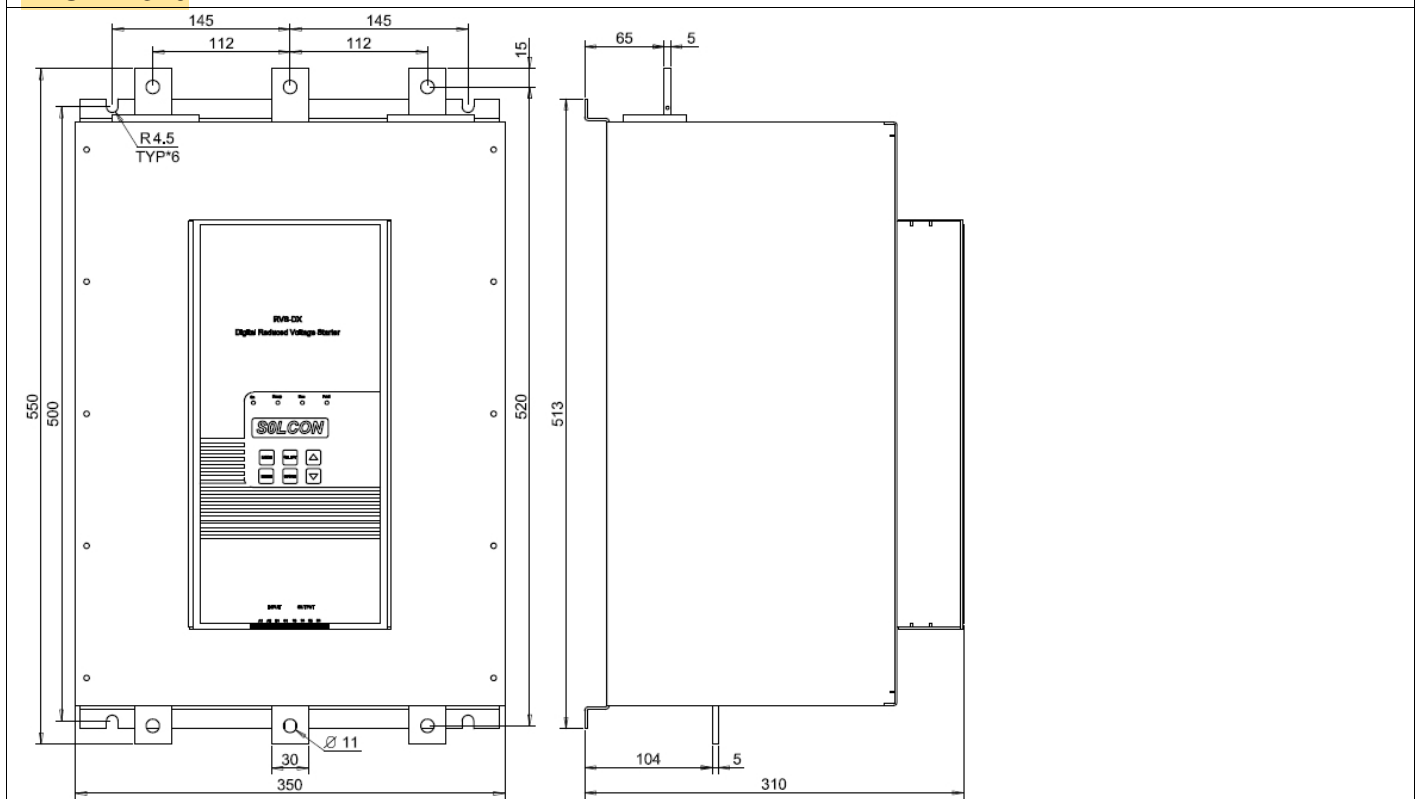

RVS-DX 390

6. INSTALLATION

WARNING!

Do not interchange line and load connections

6.1 Prior to Installation

Check that Motor's Full Load Ampere (FLA) is lower than, or equal, to the starter's Full Load Current (FLC) and that Mains and Control voltages are as indicated on the starter's side label.



RVS-DX label - example

Make sure Starter's FLC ≥ Motor FLA!
 Make sure Mains voltage is right!
 Make sure Control voltage is right!

6.2 Mounting

The starter must be mounted vertically. Allow sufficient space (at least 100mm) above and below the starter for suitable airflow.

It is recommended to mount the starter directly on the rear metal plate for better heat dissipation.

Note:

Do not mount the RVS-DX directly on the rear metal plate in case a ventilation fan or ventilation opening is on the back side of the RVS-DX.

Do not mount the starter near heat sources.

Surrounding air temperature in the cabinet should not exceed 40°C

Protect the starter from dust and corrosive atmospheres.

Note: For harsh environments (sewage treatment plants, etc.), it is recommended to order the starter with printed circuit board coating. Refer to section 3.3.6 on page 7 for ordering information.

6.3 Temperature range & heat dissipation

The starter is rated to operate over a temperature range of -10°C (14°F) to + 40°C (104°F).

Relative non-condensed humidity inside the enclosure should not exceed 95%.

ATTENTION!

Operating at surrounding air temp. (Inside the cabinet) higher than 40°C may cause damage to the starter.

Starter's heat dissipation while motor is running and the internal bypass relays are closed is typically less than 0.4 x I_n (in watts). During soft start and soft stop, heating is approximately three times the actual starting current (I_n watts).

Example: For a 100A motor, heat dissipation is less than 40 watts while running and during starting (for example at 350A), heat dissipation is approximately 1050 watts.

Important note: If motor is frequently started, cabinet should be designed for the higher heat dissipation.

Internal enclosure heating can be reduced through the use of additional ventilation.

6.3.1 Calculating the enclosure size, for non-ventilated metallic enclosure

$$\text{Area (m}^2\text{)} = \frac{0.12 \times \text{Total heat dissipation [Watts]}}{60 - \text{External ambient temp. [}^\circ\text{C]}}$$

Where: **Area [m²]** - Surface area that can dissipate heat (front, sides, top).

Total heat dissipation [Watt] – The total heat dissipation of the starter and other control devices in the enclosure. If starter is frequently started, average power should be used.

6.3.2 Additional Ventilation

Use the following arrangement for forced ventilation of the RVS-DX's enclosure:

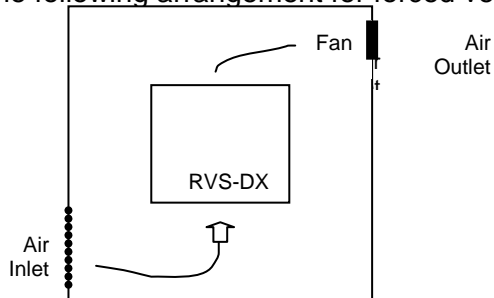

6.3.3 UL, cUL Installation Instructions

- Input power and output motor field wiring shall be copper conductors, rated 75°C.
- Use UL listed closed-loop connectors sized for the selected wire gauge. Install connectors using the correct crimp tool recommended by the connector manufacturer. Applies only to units bus bars.
- Table showing corresponding wire size, terminal screw and closed-loop connector size. Torque ratings for attachment of connector to bus bar (refer to table below).
- Branch circuit protection, shall be provided per the NEC.
- For units with UL cUL approval, refer to section **Error! Reference source not found.** on page **Error! Bookmark not defined.**

Max. Mot. FLA [A]	Min. dimensions for copper cables [mm ²]	Term Screw	Mechanical Torque [Kg.cm]
8	4 x 1.5 N2XY		
17	4 x 2.5 N2XY		
31	4 x 4 N2XY		
44	4 x 10 N2XY		
58	4 x 16 N2XY		
72	4 x 16 N2XY		
85	4 x 25 N2XY		
105	4 x 25 N2XY	M8	180
145	3 x 50 + 25 N2XY	M8	180
170	3 x 70 + 35 N2XY	M8	180
210	3 x 95 + 50 N2XY	M10	220
310	3 x 150 + 70 N2XY	M10	220
390	3 x 185 + 95 N2XY	M10	220
460	3 x 240 + 120 N2XY	M10	220
580	2 x (3x 150 + 70)N2XY	M10	220
820	3 x (3x 185+ 95) N2XY	M10	220
950			
1100			

7. CONTROL KEYPAD

The control keypad is the link between the Soft Starter and the user.

The RVS-DX control keypad features:

- (1) Two lines of 16 alphanumeric characters each (with five selectable languages – English, French, German, Spanish and Turkish)
- (2) Six push-buttons (**Mode**, **Reset**, **Select**, **Store**, Up (▲) and down (▼) keys).
- (3) Four indication LEDs (*On*, *Ramp*, *Run* and *Fault*)

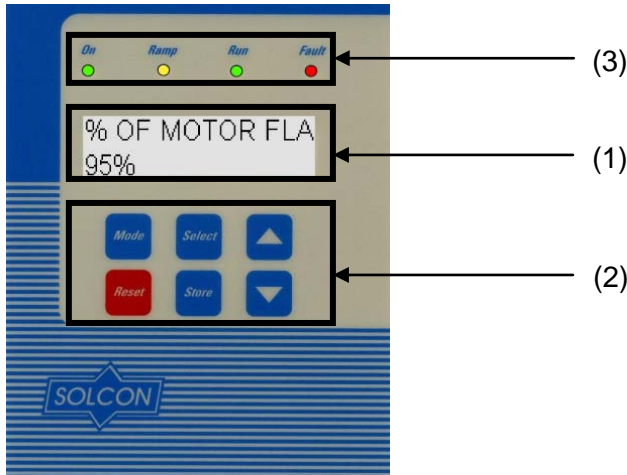

Close view

7.1 LCD Arrangement

CURRENT LIMIT
390%





Upper line displays function.

Lower line displays setting and/or measured values.

7.2 Push-buttons

Mode	Scrolls through the display and programming menus of the RVS-DX. Note: Pressing Mode continuously increases the speed at which the parameters change.
Select	When a mode name is displayed, pressing this button drills down to the parameters for that mode. When a parameter is displayed, pressing this button scrolls to the next parameter.
▲	Allows the operator to increment adjusted values shown in the display. Operator should press this button once to increment one value, or continuously to rapidly increment values up to the maximum value.
▼	Allows the operator to decrement adjusted values shown in the display. Operator should press this button once to decrement one value, or continuously to rapidly decrement values up to the minimum value.
Store	Stores modified parameters only when you have scrolled through all parameters and STORE ENABLE XXXXXX PARAMETERS is displayed. After you store a parameter successfully DATA SAVED OK will display. Note: Pressing this button at any other time has no effect.
Reset	Resets the RVS-DX after a fault has been dealt with and the start command has been removed. This cancels the fault displayed and allows you to restart the motor.

7.3 Status LEDs.

	Green	<i>On</i>	Lights when Control Supply voltage is connected to the RVS-DX.
	Yellow	<i>Ramp</i>	Lights during soft start and soft stop process, indicating that motor supply voltage is ramping up or down.
	Green	<i>Run</i>	Lights after completion of starting process, indicating that motor is receiving full voltage.
	Red	<i>Fault</i>	Lights upon operation of any of the built-in protection.

7.4 Reviewing and Modifying Parameters

Press the **Mode** key several times until you reach the required mode page.
Press the **Select** key to review parameters for this mode.

Once you reach the required parameter, use the ▼ or ▲ keys to modify its value.
To store the new parameters, press the **Select** key until the STORE ENABLE message displays and then press the **Store** key. The DATA SAVED OK message will display for 2 seconds.

7.5 Special Actions Performed in TEST/MAINTENANCE Mode

7.5.1 Run Self Test

Press the **Mode** and ▼ keys simultaneously.
The LCD will display:

```
TEST/MAINTENANCE
***OPTIONS***
```

Press the **Select** key.
The LCD will display:

```
RUN SELF TEST?
PUSH UP ARROW
```

Press the ▲ key.
The LCD will display:

```
SELF TEST PASSED
```

And after a few seconds the LCD will display:

```
% OF MOTOR FLA
I<0.1 FLC
```

7.5.2 View Software Version

Press the **Mode** and ▼ keys simultaneously.
The LCD will display:

```
TEST/MAINTENANCE
***OPTIONS***
```

Press the **Select** key **twice**.
The LCD will display:

```
BTL-R-17/05/2009
STRT.DX-310111
```

Press the **Mode** and ▼ keys simultaneously to exit the TEST/MAINTENANCE mode.
The LCD will display:

```
% OF MOTOR FLA
I<0.1 FLC
```

7.5.3 Obtain Default Parameters

Press the **Mode** and ▼ keys simultaneously.

The LCD will display:

```
TEST/MAINTENANCE
***OPTIONS***
```

Press the **Select** key **three times**.

The LCD will display:

```
STORE      ENABLE
DEFAULT PARAMET.
```

Press the **Store + Mode** keys simultaneously.

The LCD will display:

```
DATA SAVED OK
```

And after a few seconds the LCD will display:

```
% OF MOTOR FLA
I<0.1 FLC
```

CAUTION!

Obtaining DEFAULT PARAMETERS erases all previously modified settings and requires the operator to **reprogram** all parameters that differ from the factory default.

Note: It is especially important to reprogram the **FLC** (as shown on the label of the RVS-DX), **FLA** and **RATED LINE VOLT.** value again.

7.5.4 Reset Statistical Data

Press the **Mode** and ▼ keys simultaneously.

The LCD will display:

```
TEST/MAINTENANCE
***OPTIONS***
```

Press the **Select** key **four times**.

The LCD will display:

```
RESET STATISTICS
```

Press the **Reset + Store** keys simultaneously.

The LCD will display:

```
DATA SAVED OK
```

And after a few seconds the LCD will display:

```
STATISTICAL DATA
- **** -
```

Press the **Mode** and go back to:

```
% OF MOTOR FLA
I<0.1 FLC
```

7.5.5 Calibrate Voltage, Current and (Factory Use Only!)

Press the **Mode** and ▼ keys simultaneously.
The LCD will display:

```
TEST/MAINTENANCE
***OPTIONS***
```

Press the **Select** key **five times**.
The LCD will display:

```
VOLTAGE ADJUST.
X VOLT
```

Press the **Select** key.
The LCD will display:

```
CURRENT ADJUST.
5% OF FLC
```

Press the **Select** key.
The LCD will display (POWER FACTOR & POWER measurement only available in RVS-DX58A and up):

```
POWER FACTOR
0.71
```

Press the **Mode** and ▼ keys simultaneously to exit the TEST/MAINTENANCE mode.

7.6 Mode Pages

Upon initiation of the starter, the LCD displays motor's operating current:

```
% OF MOTOR FLA
0%
```

By pressing the **Mode** key all mode pages can be reviewed:

```
MAIN PARAMETERS
- **** -
```

```
START PARAMETERS
- **** -
```

```
STOP PARAMETERS
- **** -
```

```
DUAL ADJUSTMENT
PARAMETERS
```

```
SPECIAL FEATURES
PARAMETERS
```

```
FAULT PARAMETERS
- **** -
```

```
I/O PROGRAMMING
PARAMETERS
```

```
COMM PARAMETERS
- **** -
```

```
STATISTICAL DATA
- **** -
```

These pages are skipped if RVS-DX is programmed to "MINIMIZED MODE" and are shown only in "MAXIMIZED MODE" (Refer to section 7.6.3 on page 27 for information on changing from "MINIMIZED MODE" to "MAXIMIZED MODE")